



Assessment of Targeted Next-Generation Sequencing as a Tool for the Diagnosis of Charcot-Marie-Tooth Disease and Hereditary Motor Neuropathy

Vincenzo Lupo,^{*†‡} Francisco García-García,^{§¶} Paula Sancho,^{*†} Cristina Tello,^{*} Mar García-Romero,^{||} Liliana Villarreal,^{**} Antonia Alberti,^{††} Rafael Sivera,^{‡‡} Joaquín Dopazo,^{§¶§§} Samuel I. Pascual-Pascual,[¶] Celedonio Márquez-Infante,^{||} Carlos Casanovas,^{††} Teresa Sevilla,^{‡‡¶¶|||} and Carmen Espinós^{*†‡}

From the Unit of Genetics and Genomics of Neuromuscular Disorders,* Program in Rare and Genetic Diseases and IBV/CSIC Associated Unit, Centro de Investigación Príncipe Felipe (CIPF), Valencia; Units 732,[†] 715,[§] and 763,^{¶¶} Centro de Investigación Biomédica en Red de Enfermedades Raras (CIBERER), Valencia; the Department of Genomics and Translational Genetics,[‡] Centro de Investigación Príncipe Felipe (CIPF), Valencia; the Unit of Systems Biology,[¶] Program in Computational Genomics, Centro de Investigación Príncipe Felipe (CIPF), Valencia; the Department of Neuropediatrics,^{||} Hospital Universitario La Paz, Madrid; the Department of Neurology,^{**} Hospital Universitario Virgen del Rocío, Seville; the Department of Neurology,^{††} Hospital de Bellvitge, Barcelona; the Department of Neurology,^{‡‡} Hospital Universitari i Politènic La Fe and Instituto de Investigación Sanitario (IIS) – La Fe, Valencia; the Functional Genomics Node,^{§§} Spanish National Institute of Bioinformatics (INB), Valencia; and the Department of Medicine,^{|||} Universitat de València, Valencia, Spain

Accepted for publication
October 14, 2015.

Address correspondence to
Carmen Espinós, Ph.D., Centro
de Investigación Príncipe
Felipe (CIPF), c/ Eduardo
Primo Yúfera, 3, 46012
Valencia, Spain. E-mail:
cespinos@cipf.es.

Charcot-Marie-Tooth disease is characterized by broad genetic heterogeneity with >50 known disease-associated genes. Mutations in some of these genes can cause a pure motor form of hereditary motor neuropathy, the genetics of which are poorly characterized. We designed a panel comprising 56 genes associated with Charcot-Marie-Tooth disease/hereditary motor neuropathy. We validated this diagnostic tool by first testing 11 patients with pathological mutations. A cohort of 33 affected subjects was selected for this study. The *DNAJB2* c.352+1G>A mutation was detected in two cases; novel changes and/or variants with low frequency (<1%) were found in 12 cases. There were no candidate variants in 18 cases, and amplification failed for one sample. The *DNAJB2* c.352+1G>A mutation was also detected in three additional families. On haplotype analysis, all of the patients from these five families shared the same haplotype; therefore, the *DNAJB2* c.352+1G>A mutation may be a founder event. Our gene panel allowed us to perform a very rapid and cost-effective screening of genes involved in Charcot-Marie-Tooth disease/hereditary motor neuropathy. Our diagnostic strategy was robust in terms of both coverage and read depth for all of the genes and patient samples. These findings demonstrate the difficulty in achieving a definitive molecular diagnosis because of the complexity of interpreting new variants and the genetic heterogeneity that is associated with these neuropathies. (*J Mol Diagn* 2016, 18: 225–234; <http://dx.doi.org/10.1016/j.jmoldx.2015.10.005>)

Charcot-Marie-Tooth (CMT) disease is the most frequently inherited neurological disorder and has a prevalence of 1 in 2500 population.¹ CMT displays broad genetic heterogeneity with a common clinical phenotype. Because both motor and sensory nerves are affected, CMT is also categorized as a hereditary motor and sensory neuropathy. When only motor nerves are affected, it is called a hereditary motor neuropathy (HMN), which corresponds to the pure motor forms. CMT can be subclassified into three

Supported by grants IR11/TREAT-CMT (C.E., C.C., C.M.-I., S.I.P.-P.) and PI12/00453 (C.E.) from the Instituto de Salud Carlos III (ISCIII)—Subdirección General de Evaluación y Fomento de la Investigación within the framework of the National R + D + I Plan, cofunded by the European Regional Development Fund. This collaborative joint project was awarded by the International Rare Diseases Research Consortium. C.E. has a “Miguel Servet” contract funded by grant CPII14/00002 from the ISCIII and the Centro de Investigación Príncipe Felipe (CEPF). The Centro de Investigación Biomédica en Red de Enfermedades Raras is an initiative of the ISCIII.

Disclosures: None declared.

Table 1 Control Group: Clinical Form and Genetic Characteristics

ID no.	Clinical form	Inheritance	Carrier status	Gene	Nucleotide change	Amino acid change	Reference
SGT-036	CMT2	AD	Heterozygosis	<i>MFN2</i>	c.310C>T	p.R104W	10
DNA_121	CMT1	AD	Heterozygosis	<i>MPZ</i>	c.21_26dupTGCCC	p.P9_A10dup	8
DNA_837	CMT2	X-linked	Hemizygosis	<i>GJB1</i>	c.44_45delinsTT	p.R15L	8
DNA_872	CMT2	X-linked	Hemizygosis	<i>GJB1</i>	c.-540G>C	No aa change	8
DNA_554	CMT1	AR	Compound heterozygosis	<i>PRX</i>	c.642insC c.589G>T	p.R215QfsX8 p.E197X	8 8
DNA_571	CMT1	AR	Homozygosis	<i>FGD4</i>	c.1886delGAAA	p.K630NfsX5	8
DNA_223	CMT1	AD	Heterozygosis	<i>GARS</i>	c.1171C>T	p.R391C	8
DNA_708	CMT2	AR	Compound heterozygosis	<i>GDAP1</i>	c.172_173delCTinsTTA c.311-1G>A	p.P59AfsX4 No aa change	11 12
SGT-047	CMT1	AR	Homozygosis	<i>HK1</i>	g.9712G>C	No aa change	13, 14
SGT-044	CMT1	AR	Compound heterozygosis	<i>SH3TC2</i>	c.3325C>T	p.R1109X	13, 14
					c.3325C>T	p.R1109X	13, 14
DNA_621	CMT1	AD	Heterozygosis	<i>HSPB1</i>	c.2211_2213delCCC	p.C737_P738delinsX	13, 14
					c.418C>G	p.R140G	15

DNAs indicated with the code SGT or DNA were studied for segregation analysis.

AD, autosomal dominant; AR, autosomal recessive; CMT1, Charcot-Marie-Tooth disease type 1; Charcot-Marie-Tooth disease type 2.

types. The first is demyelinating CMT (CMT1), in which median motor nerve conduction velocities (MMNCVs) are slowed (<38 meters per second) and which primarily results in demyelinating neuropathy. The second is axonal CMT (CMT2), with preserved or mildly slowed MMNCVs (>38 meters per second) and which largely results in axonal loss. The third is intermediate CMT, for which the MMNCVs range from 25 to 45 meters per second and the nerve pathology shows signs of demyelinating and/or axonal features.²⁻⁴

The list of genes involved in CMT is ever-growing and currently comprises >50 genes (Neuromuscular Disease Center, <http://neuromuscular.wustl.edu/time/hmsn.html>, last accessed October 5, 2015). There is a clear overlap between HMN and CMT, and the same mutation in a gene can cause both phenotypes. Nearly 22 known genes are associated with HMN, and mutations in at least eight of them are related to CMT.⁵ All of the Mendelian patterns of inheritance are observed in CMT/HMN diseases. Sporadic cases may occur as the consequence of a *de novo* mutation and, therefore, do not exhibit a family history of neuropathy.⁵⁻⁷

Molecular diagnosis is a relevant and integral part of clinical diagnosis. The successful diagnosis of hereditary neuropathies and other Mendelian diseases has greatly improved over the past 5 years. These advances are mainly due to next-generation sequencing, which has resulted in the discovery of hundreds of genes involved in human diseases. Approximately 80% of CMT1 patients can now receive an accurate molecular diagnosis. There is a high percentage of CMT2 (between 25% and 43%) in unresolved clinical cases.⁶⁻⁹ Additionally, 80% of HMN patients remain molecularly undiagnosed.⁵ Determining which gene needs to be tested in each patient is difficult, and usually only the most common genes are analyzed. The turnaround time and the cost of the tests are also important factors. We have designed a panel based on targeted next-generation

sequencing for the molecular diagnosis of CMT and HMN. The panel contains 56 genes involved in CMT/HMN and provides a cost-efficient alternative to conventional Sanger-based methods.

Materials and Methods

Patients

Forty-four unrelated patients with a diagnosis of CMT or HMN were selected. These patients were evaluated by neurologists at the Spanish Consortium on CMT [TREAT-CMT, <http://www.treat-cmt.es/db> (login required), last accessed July 5, 2015].⁸ Based on their clinical history and electrophysiological and histopathological criteria, patients were subclassified into one of four groups: HMN, CMT1, CMT2, or intermediate CMT. Whenever possible, relatives of the patients were studied for segregation analysis.

All of the patients and relatives included in this study gave informed consent, and the research protocols were approved by the Institutional Review Boards or the ethics committees of the Hospital Universitario La Paz (Madrid, Spain), the Hospital Universitario Virgen del Rocío (Seville, Spain), the Hospital de Bellvitge (Barcelona, Spain), and the Hospital Universitari i Politècnic La Fe (Valencia, Spain).

Control Group and Unscreened CMT/HMN Patients

The 44 patients were divided into two groups. The first included 11 patients with known disease-causing mutations and was used as a control group to verify the reliability of our custom panel diagnostic strategy. It also included 33 patients without a genetic diagnosis.

The control group included 11 carriers of 14 different types of mutations (indels, duplications, missense, frameshifts, and regulatory variants) located in several genes involved in

Table 2 Target Genes Included in the Panel

Gene	Ref sequence	MIM No.	Region	Gene	Ref sequence	MIM No.	Region
<i>AARS</i>	NM_001605.2	601065	20	<i>LITAF</i>	NM_004862.3	603795	4
<i>ATP7A</i>	NM_000052.6	300011	22	<i>LMNA</i>	NM_170707.2	150330	14
<i>BICD2</i>	NM_015250.3	615290	8	<i>LRSAM1</i>	NM_138361.5	610933	24
<i>BSC12</i>	NM_001122955.3	606158	11	<i>MARS</i>	NM_004990.3	156560	21
<i>DCTN1</i>	NM_004082.4	601143	32	<i>MED25</i> [†]	NM_030973.3	610197	1
<i>DHTKD1</i>	NM_018706.6	614984	17	<i>MFN2</i>	NM_014874.3	608507	17
<i>DNAJB2</i>	NM_006736.5	604139	9	<i>MICAL1</i>	NM_001286613.1	607129	24
<i>DNM2</i>	NM_001005360.2	602378	22	<i>MPZ</i>	NM_000530.6	159440	7
<i>DYNC1H1</i>	NM_001376.4	600112	78	<i>MTMR2</i>	NM_016156.5	603557	15
<i>EGR2</i>	NM_000399.3	129010	2	<i>NDRG1</i>	NM_001135242.1	605262	15
<i>FBLN5</i>	NM_006329.3	604580	11	<i>NEFL</i>	NM_006158	162280	4
<i>FGD4</i>	NM_139241.2	611104	15	<i>PDK3</i>	NM_001142386.2	300906	12
<i>FIG4</i>	NM_014845.5	609390	23	<i>PLEKHG5</i>	NM_198681.3	611101	25
<i>GAN</i>	NM_022041.3	605379	11	<i>PMP22</i>	NM_000304.2	601097	4
<i>GARS</i>	NM_002047.2	600287	17	<i>PRPS1</i>	NM_002764.3	311850	7
<i>GDAP1</i>	NM_018972.2	606598	6	<i>PRX</i>	NM_181882.2	605725	4
<i>GJB1</i> [*]	NM_000166.5	304040	2	<i>RAB7A</i>	NM_004637.5	602298	5
<i>GNB4</i>	NM_021629.3	610863	9	<i>SBF1</i>	NM_002972.2	603560	41
<i>HARS</i>	NM_002109.5	142810	13	<i>SBF2</i>	NM_030962.3	607697	40
<i>HINT1</i>	NM_005340	601314	3	<i>SETX</i>	NM_015046.5	608465	24
<i>HK1</i> [†]	NM_000188.2	142600	1	<i>SH3TC2</i>	NM_024577.3	608206	17
<i>HSPB1</i>	NM_001540.3	602195	3	<i>SLC12A6</i>	NM_133647.1	604878	26
<i>HSPB3</i>	NM_014365.2	604624	1	<i>TDP1</i>	NM_018319.3	607198	15
<i>HSPB8</i>	NM_014365.2	608014	3	<i>TFG</i>	NM_006070.5	602498	7
<i>IGHMBP2</i>	NM_002180.2	600502	15	<i>TRIM2</i>	NM_015271.4	614141	12
<i>KARS</i>	NM_001130089.1	601421	15	<i>TRPV4</i>	NM_021625.4	605427	15
<i>KIF1B</i>	NM_015074.3	605995	47	<i>TUBA8</i>	NM_018943.2	605742	5
<i>KIF5A</i>	NM_004984.2	602821	28	<i>YARS</i>	NM_003680.3	603623	13

*Promoter sequence included.

[†]Only founder mutations were analyzed.

MIM, Mendelian Inheritance in Man.

CMT1 or CMT2 (Table 1),^{8,10–15} These mutations were identified by Sanger sequencing of the codified regions of the respective genes.

The group of affected individuals without a molecular diagnosis included 33 CMT or HMN patients, distributed as follows: two CMT1, 20 CMT2, nine HMN, and two intermediate CMT. In these patients, the CMT1A duplication was verified by multiplex ligation–dependent probe amplification (Salsa Kit P033B CMT1/HNPP region; MRC-Holland, Amsterdam, the Netherlands) before testing and was subsequently discarded. For the majority of patients, at least mutations in the genes that are frequently involved in CMT disease (*PMP22*, *MPZ*, *GJB1*, *GDAP1*, and *MFN2*) were also ruled out by Sanger sequencing of exons and their intronic flanking sequences.

Gene Panel Design

Table 2 shows the 56 genes included in our panel. All of these genes are involved in CMT and/or HMN. The clinical and genetic features of 54 genes have been described by the Neuromuscular Disease Center (<http://neuromuscular.wustl.edu/time/hmsn.html>, last accessed January 20, 2015). The

features of two genes, *MICAL1* and *TUBA8*, were communicated at the Fifth International CMT Meeting,^{16,17} and these genes were also included because they were reported to be involved in CMT disease.

The panel of genes was generated using Agilent's Sure-Design tool (Agilent Technologies Inc., Santa Clara, CA). For the capture design, we included all exons plus 25 bp of intronic flanking regions of the genes, taking into account different isoforms, except for two genes, *HK1* and *MED25*. For both of these, we exclusively covered the analysis of the amplicon that contains the founder mutation described for them (*HK1* g.9712G>C and *MED25* p.A335V). Finally, we also added the promoter region of the *GJB1* gene, because four causative mutations have been reported for it.^{8,18,19} Taken together, we generated a panel of 56 genes comprising 57 targets that are divided into 862 regions with 8383 of total amplicons and a size of 186.34 Kbp. The theoretical target coverage was 99.98%.

Samples

DNA from patients and relatives was previously extracted from blood samples using a Gentra Puregene blood kit

Table 3 Primers and PCR Conditions

Marker	Forward primer	Reverse primer	Ta (°C)
STR markers			
<i>D2S2250</i>	5'-CTGAAACTCACCGAACACC-3'	5'-CCCAAATAGGCAGGGAAAT-3'	55
<i>D2S2244</i>	5'-AGCTGCTCAGGGGGACT-3'	5'-CAGGTGGCAACATTTTACCAT-3'	65
SNP markers			
rs8447	5'-ACAGGCATTCTTCAGCATTG-3'	5'-CCAGATTTGGAGTCAGAACAC-3'	60
rs10166888	5'-AGCAACATGACAGCCATCAC-3'	5'-AGACAATAAGGCCACAGCAC-3'	60
rs2276638	5'-TACATGTGGTCCCAGCACT-3'	5'-TGATAGAACCTGCCTCATAGG-3'	65
rs115665065			
rs3731896	5'-GCTGAGTTGCTGCCCTAACCT-3'	5'-CTTCTGTCCGTGGCATTCC-3'	60
rs3832110			
rs202090561			
rs3731897			
rs2276639	5'-CTGAAAGAGCCATCTGTCT-3'	5'-AACGAGCAGTGACAGAATCCT-3'	60
rs140419734			
rs3821038			
rs3821039			
rs2385405	5'-CAAGTTTCTTAGCCTTGAGG-3'	5'-AGGAGGGTTAACAGATTCG-3'	60
rs2385404			

For SNP markers primers were used at 0.2 $\mu\text{mol/L}$. For *D2S2250* and *D2S2244* STR markers, primers were used at 0.1 $\mu\text{mol/L}$ and 0.05 $\mu\text{mol/L}$, respectively. SNP, single-nucleotide polymerase; STR, single tandem repeat; Ta, temperature of annealing.

(Qiagen, Venlo, the Netherlands). All DNA samples were repurified and re-eluted in nuclease-free water using the QIAamp DNA micro kit (Qiagen). The quantity and quality of the genomic DNA were determined using both the NanoDrop and the Qubit dsDNA BR in a Qubit 2.0 fluorometer (all from Thermo Fisher Scientific Inc., Rochester, NY). Agarose gel electrophoresis was used for validating the integrity of DNA.

Sequence Capture and Next-Generation Sequencing

Sequence capture was performed using the HaloPlex Target Enrichment System (protocol version D.5; Agilent Technologies Inc.) for Illumina Sequencing (Illumina Inc., San Diego, CA). Approximately 300 ng of each genomic DNA sample was digested. The genomic DNA fragments were then hybridized to the HaloPlex probe capture library and Illumina sequencing motifs including index sequences. Subsequently, target DNA-HaloPlex probe hybrids were biotinylated and captured on streptavidin beads. The captured target library was amplified according to the manufacturer's instructions and subsequently purified using AMPure XP beads (Beckman Coulter Inc., Pasadena, CA). Before sample pooling and sequencing, quality-control stops were included to evaluate and control for possible contamination and errors: the success of genomic DNA restriction digestion using an enrichment control DNA, and the validation and quantification of the enriched target DNA in each library sample, the amplicons of which should have ranged from 175 to 625 bp in length, with the majority of products sized 225 to 525 bp. Both of them were performed using a Bioanalyzer High Sensitivity DNA Kit and the

2100 Bioanalyzer with 2100 Expert software version B.02.08SI648 (Agilent Technologies Inc.). An enrichment control DNA sample was used during the procedure. Finally, four different runs were processed using a 300-cycle MiSeq Reagent Kit version 2 (Illumina Inc.) on an Illumina sequencing platform. The read length was 150 bp. For each run, 11 samples were pooled for multiplexed sequencing. Sequence data have been deposited into the Sequence Read Archive repository (<http://www.ncbi.nlm.nih.gov/sra>; accession number SRP061110).

Statistical Analysis

To evaluate the sequencing coverage, we used BAM files to generate coverage indicators from the Genome Analysis Toolkit (GATK) version 3.0 (<https://www.broadinstitute.org/gatk>).²⁰ Clustering and principal component methods were performed to determine the coverage data for all of the samples. Boxplots, scatterplots, and statistics were used for describing coverage by gene and by regions. Bar graphs described the mean coverage for each region and each gene. The statistical software R version 3.2.0 was used for performing this analysis (<http://www.r-project.org>). Quality metrics for sequence processing, mapping, and calling variants were calculated using the FastQC (<http://www.bioinformatics.babraham.ac.uk/projects/fastqc>), SAMStat (<http://samstat.sourceforge.net>, all last accessed September 16, 2015), and Variant tools.²¹

Data Analysis

Data were analyzed using a platform provided by DNAnexus (Mountain View, CA). Annotated variants that had a quality

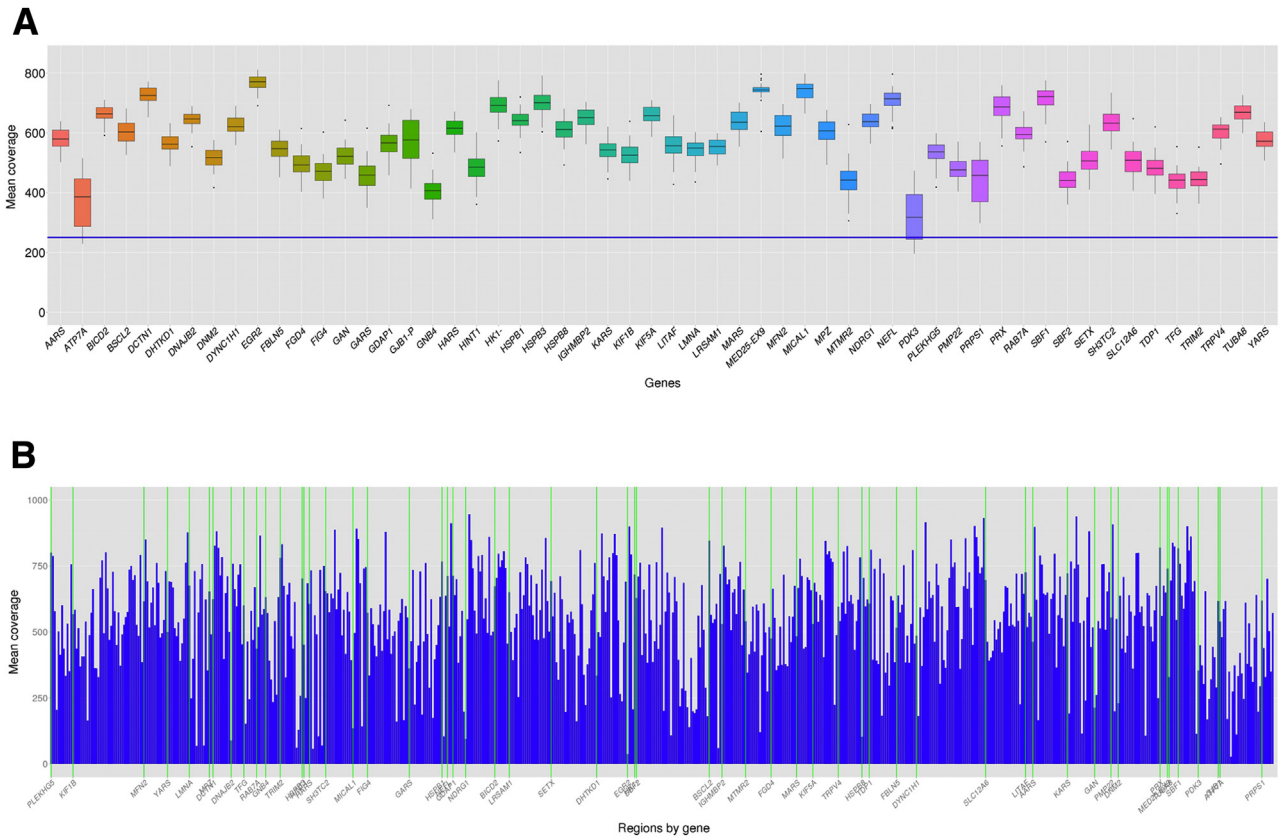

Figure 1 Depth of coverage by gene (A) and regions (B). A: The horizontal blue line is fixed at 250 \times . B: The green bars delimitate regions of the genes, and the blue bars represent the regions.

value of ≥ 250 and a percentage of heterozygosity of $\geq 30\%$ of the reads were selected. To filter out common single-nucleotide polymorphisms (SNPs) and indels with allele frequency cutoffs of 0.01, we used the following databases: dbSNP (<http://www.ncbi.nlm.nih.gov/SNP>), ESP6500 (<http://evs.gs.washington.edu/EVS>), GEM.app (<https://genomics.med.miami.edu>), ExAC (<http://exac.broadinstitute.org>), and CSVS (<http://csvs.babelomics.org>, all last accessed September 16, 2015). Variant annotations of interest were performed according to the gene reference sequence reported in Table 2.

All changes detected with a minor allele frequency of $< 1\%$ were validated by Sanger sequencing on a 3730xl DNA analyzer (Applied Biosystems Inc., Foster City, CA). Whenever possible, segregation analysis was performed.

In silico analysis was performed to predict the phenotypical consequences of the novel and low-frequency variants, using the SIFT (<http://sift.bii.a-star.edu.sg>) and PolyPhen-2 (<http://genetics.bwh.harvard.edu/pph2>) algorithms. Moreover, possible splicing process alterations were evaluated using NNSPLICE version 0.9 (http://www.fruitfly.org/seq_tools/splice.html), Human Splicing Finder (<http://www.umd.be/HSF>), and RESCUE-ESE (<http://genes.mit.edu/burgelab/rescue-ese>, all last accessed September 16, 2015). According to the recommendations of the American College

of Medical Genetics,²² novel or low-frequency SNP variants were classified as benign, likely benign, likely pathogenic, pathogenic, or as variants of uncertain significance.

Haplotype Analysis

The study subjects included in the haplotype analysis of the *DNAJB2* locus were homozygous for the *DNAJB2* c.352+1G>A mutation and some relatives from families fCMT-83 and fCMT-391 (Supplemental Table S1). Haplotypes were constructed with 10 intragenic SNPs. To refine the critical interval, two extragenic single tandem repeats and four SNPs were analyzed: cen_D2S2250-rs8447-rs10166888-rs2276638-rs115665065-rs3731896-rs3832110-rs202090561-rs3731897-rs2276639-rs140419734-rs3821038-rs3821039-rs2385405-rs2385404-D2S2244_tel. SNPs and single tandem repeats were obtained from the University of California at Santa Cruz Genome Bioinformatics site (<http://genome.ucsc.edu>, last accessed January 20, 2015) and GeneLoc (<http://genecards.weizmann.ac.il/geneloc/index.shtml>, last accessed January 20, 2015).

For single tandem repeat markers, after generating 25 μ L of PCR product using specific primers, each sample was diluted with 100 μ L of water. Next, a mix of 1.4 μ L of sample plus 5 μ L of formamide and 0.5 μ L

Table 4 Variants with a Minor Allele Frequency of <1%

ID no.	Clinical form	Inheritance	Gene	dbSNP/1000G/ExAC/CSVS	Nucleotide change	Amino acid change	Segregation analysis	ACMG score
SGT-019	HMN	AR	<i>DNAJB2</i>	Novel*	c.352+1G>A	No aa change	Yes (Figure 2)	Pathogenic
SGT-018	HMN	AR	<i>PLEKHG5</i>	rs140202670/ 0.0023/0.001/ 0.0005	c.1225C>T	p.Arg409Trp	Negative	Benign
			<i>SBF1</i>	rs201776298/ 0.0045/0.0023/ Novel	c.868G>A	p.Ala290Thr	Negative	Benign
SGT-031	CMT2	AD	<i>MICAL1</i>	rs201447051/ 0.0014/ 2.492e-05/ Novel	c.374T>C	p.Leu125Pro	Yes (Supplemental Figure S1)	Likely pathogenic
SGT-029	I-CMT	Sporadic	<i>PLEKHG5</i>	Novel/Novel/ 2.951e-05/ Novel	c.800G>A	p.Arg267His	Negative	VUS
			<i>SETX</i>	rs148568105/ Novel/0.00016/ Novel	c.6013G>A	p.Val2005Met	Negative	VUS
SGT-030	CMT2	Probably AD	<i>KIF1B</i>	rs121908162/ 0.0009/0.0006/ Novel	c.2480C>T	p.Thr827Ile	NA	VUS
SGT-068	CMT2	Sporadic	<i>PRX</i>	Novel	c.4077_4079delGGA	p.Glu1360del	Negative	VUS
			<i>SLC12A6</i>	Novel	c.1421A>G	p.His474Arg	Negative	VUS
SGT-072	CMT2	Sporadic	<i>IGHMBP2</i>	Novel	c.1582G>A	p.Ala528Thr	NA	VUS
SGT-139	CMT2	AD	<i>HARS</i>	Novel	c.989A>G	p.Tyr330Cys	Yes (Supplemental Figure S1)	Likely pathogenic
			<i>HARS</i>	Novel/Novel/ 4.942e-05/ 0.004	c.679T>G	p.Ser227Ala	Yes (Supplemental Figure S1)	VUS
SGT-142	CMT2	AD	<i>MFN2</i>	rs140234726/ Novel/0.00028/ Novel	c.749G>A	p.Arg250Gln	Negative	VUS
			<i>LRSAM1</i>	Novel	c.2137_2143delA-TCGCCC	p.Ile713_Gln715fsX20	Yes (Supplemental Figure S1)	Likely pathogenic
SGT-106	CMT2	AD	<i>LRSAM1</i>	Novel	c.2083_2094delTG-CTGCCAGCAG	p.Cys696_Cys699del	Inconclusive (Supplemental Figure S1)	VUS
SGT-109	CMT2	AD	<i>PLEKHG5</i>	Novel	c.718G>A	p.Asp240Asn	NA	VUS
SGT-114	I-CMT	Probably AD	<i>SETX</i>	Novel	c.4289C>T	p.Ser1430Phe	Negative	VUS
SGT-169	HMN	AR	<i>DNAJB2</i>	Novel*	c.352+1G>A	No aa change	Yes (Figure 2)	Pathogenic
SGT-170	CMT2	AR	<i>AARS</i>	rs138081804/ 0.0009/0.0005/ 0.004	c.2185C>T	p.Arg178Trp	NA	VUS
			<i>KARS</i>	Novel	c.1603C>T	p.Arg535Trp	NA	VUS

*This mutation has not been annotated in the databases, although it has been reported by Blumen et al.²⁶

ACMG, American College of Medical Genetics; AD, autosomal dominant; AR, autosomal recessive; CMT2, Charcot-Marie-Tooth disease type 2; I-CMT, intermediate Charcot-Marie-Tooth disease; HMN, hereditary motor neuropathy; NA, DNAs unavailable from relatives; VUS, variant of uncertain significance; Yes, change cosegregates with disease.

of LIZ500 size standard (Thermo Fisher Scientific Inc.) was analyzed by ABI Prism 3730xl (Applied Biosystems Inc.). The results were analyzed using the GeneMapper software version 3.7 (Applied Biosystems

Inc.). SNP markers were investigated by Sanger sequencing on an Applied Biosystems 3730xl DNA analyzer. All primers and PCR conditions are indicated in Table 3.

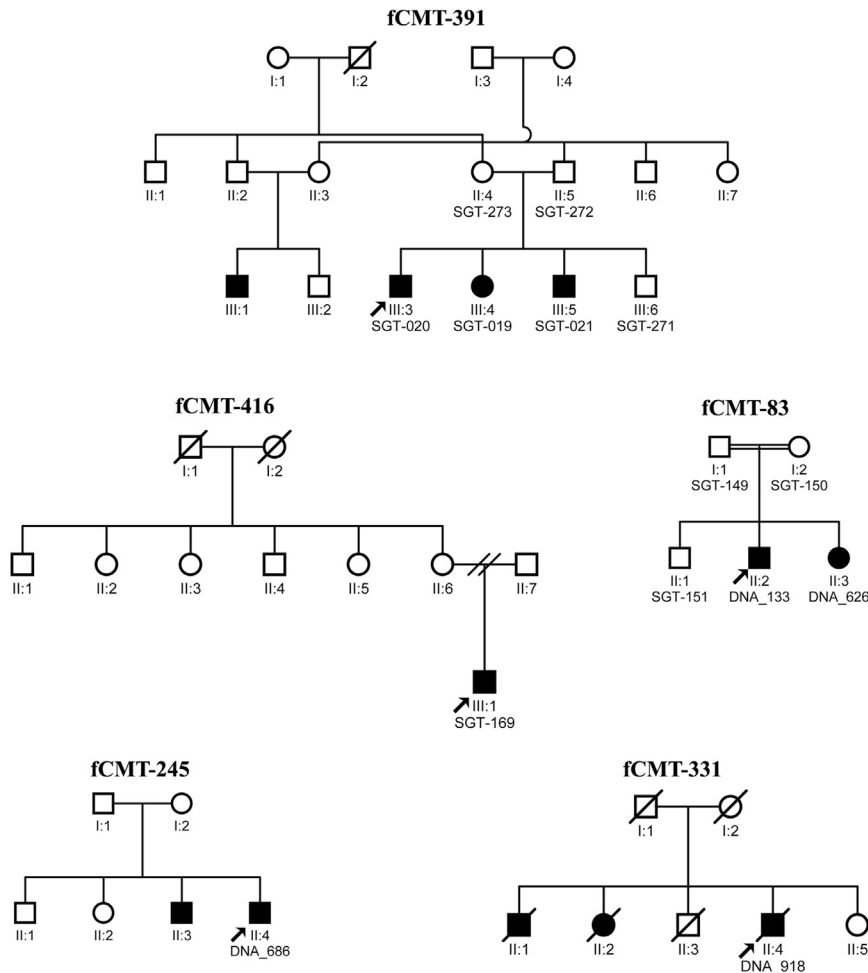

Figure 2 Hereditary motor neuropathy families carrying the *DNAJB2* c.352+1G>A mutation. The causative mutation was identified by the presented gene panel in fCMT-391 and fCMT-416; by a mutational screening using Sanger sequencing in fCMT-245 and fCMT-331; and by exome sequencing in fCMT-83. **Arrows** indicate the probands that were investigated by the HaloPlex gene panel (protocol version D.5; Agilent Technologies Inc, Santa Clara, CA). The remaining DNAs indicated with the code SGT or DNA were studied for segregation analysis.

Results

Coverage Performance Results

The capture by our custom gene panel was performed with a uniform coverage and high read depths in all samples. A mean coverage of $>250\times$ was achieved for all of the target genes (Figure 1A). The mean coverage for regions was 548.2, the median was 569.5, and the minimum was 27.1 (Figure 1B). The coverage was consistent for multiple runs on the sequencing platform. The mean coverage ranged from 531.8 to 550 for all four runs, and the rank for the median coverage was between 550.9 and 570.4. All of the detailed results regarding sequence processing, mapping, calling, and coverage analysis are available in Supplemental Tables S2–S6.

Validation of the Tool

The 14 different mutations from 11 patients (Table 1) were successfully detected using our designed gene panel. In samples in which the most frequent CMT genes were screened, we were able to confirm known polymorphisms and did not detect any other variant as

false negative. Our gene panel shows good sensitivity and specificity.

In the 33 samples from unrelated CMT/HMN patients, all of the variants detected with a minor allele frequency of $<1\%$ were confirmed by Sanger sequencing, discarding false-positive cases.

Patients

A total of 33 samples from unrelated CMT/HMN patients were analyzed. For one sample (3.0%), the capture and amplification of the library failed. For two cases (6.1%), a known pathogenic mutation was detected. In 12 cases (36.4%), novel changes and/or variants annotated with a frequency of $<1\%$ were detected (TREATCMT, <http://www.treat-cmt.es/db>) (Table 4). Lastly, in 18 cases (54.5%), no candidate changes were identified.

In two unrelated individuals, SGT-169 (fCMT-416) and SGT-019 (fCMT-391), the same pathogenic mutation, *DNAJB2* c.352+1G>A, was identified in homozygosity (Table 4 and Figure 2). Segregation analysis performed in the family fCMT-391 revealed that the detected mutation fully cosegregated with disease. We further performed a mutational screening of the *DNAJB2* c.352+1G>A change in a clinical

series without a molecular diagnosis. We identified this same mutation in two unrelated patients (Figure 2). Another family (Figure 2) was diagnosed by exome sequencing. All of these patients presented with an HMN phenotype, except for individuals from families who were first diagnosed with CMT2 (fCMT-83 and fCMT-331). Haplotype analysis showed that all of the affected subjects shared the same homozygous haplotype for the studied markers, encompassing rs8447 to rs2385404 (Supplemental Table S1); therefore, the *DNAJB2* c.352+1G>A mutation can be postulated as a founder event in our population.

In addition, 18 different heterozygous changes, 9 of which are novel mutations and could be the disease-causing mutation, were identified in 12 cases (Table 4). According to the American College of Medical Genetics score classification, we found that 3 mutations were likely pathogenic, 13 were variants of uncertain significance, and 2 were benign.

Of the 12 cases, relatives' DNAs were not available in 3 cases, and in 5 cases, the segregation analysis discarded the putative mutations (Table 4). Finally, a putative mutation that cosegregated with disease was detected in four cases, although for SGT-106, the segregation analysis was not conclusive because two individuals (SGT-342 and SGT-343) were not clinically assessed (Table 4 and Supplemental Figure S1). For all of these cases, the candidate disease-causing mutation was likely pathogenic (SGT-031, SGT-139, and SGT-142) or a variant of uncertain significance (SGT-106), and all of them are novel variants, except for the *MICAL1* c.374T>C variant (SGT-031). The findings obtained with SGT-142 deserve special attention because two possible mutations were identified: *LRSAMI* c.2137_2143delATCGCCC, which cosegregates with disease, and *MFN2* c.749G>A, which was detected only in the proband and in her son (Supplemental Figure S1).

Discussion

We developed a targeted method that tests 56 genes based on HaloPlex technology for the molecular diagnosis of CMT/HMN. All of the genes included in this panel completely lack certain hotspot regions, and some of them are particularly large; consequently, automated sequencing based on the Sanger method is very time-consuming and labor intensive. Targeted capture followed by sequencing of selected genomic regions provides an attractive and cost-effective alternative. Our panel was first tested in a group of 11 patients with a genetic diagnosis, and all of the pathogenic mutations and benign polymorphisms were identified. Similar strategies have been successfully used for identifying rare variants in breast and ovarian cancers.²³ In such studies, large numbers of candidate genes are investigated. The HaloPlex system has been previously reported as an effective and reliable approach for variant detection in leukemia, in Mendelian

Parkinson disease, and in arrhythmogenic right ventricular cardiomyopathy.^{24–26}

Our gene panel allowed us to identify the previously described *DNAJB2* c.352+1G>A mutation in two cases.²⁷ According to the results generated by parallel studies, we conclude that patients from five families present this mutation. The *DNAJB2* c.352+1G>A change was first reported in patients affected by HMN from one Moroccan family of Jewish ancestry.²⁷ The haplotype analysis revealed that all of the patients share the same homozygous haplotype, which suggests that *DNAJB2* c.352+1G>A is a founder event in our population. The common homozygous haplotype generated in the families we studied is narrower than that in the family reported by Blumen et al.²⁷ This finding suggests more recent recombination events in Spanish families. Three of the reported families are from the same town in the province of Alacant (fCMT-83, fCMT-391, and fCMT-331) and two are from Andalusia (fCMT-416 and fCMT-245). The studied families do not share last names. However, four of these families could be of Jewish origin according to their last names, as the family reported.²⁷ Technically, our next-generation sequencing diagnostic strategy proved to be robust in terms of coverage and read depth for all of the genes and patient samples. The results of this study demonstrate two main features: 36.4% of cases presented novel changes or variants with a very low frequency, and 54.5% of cases did not present any putative change to be the disease-causing mutation. In a study focusing on the genetic diagnosis of CMT in a population using a gene panel,²⁸ 20% of the cases still lacked a clear genetic diagnosis because the implications of the detected mutations were unclear, and 43% of the cases had no candidate mutation.

Regardless of which method is used, the foundation of genetic diagnosis is interpretation of the results. An increased presence of heterozygous nonsynonymous variations in a gene demonstrates the challenge of pinpointing which nucleotide change is involved in disease. When >50 genes are screened, the number of unclear variants can be overwhelming. It is not possible to perform functional studies for every identified candidate variant to determine its effect on protein function. *In silico* tools can help us to prioritize possible disease-causing mutations.²⁹ Two changes, classified as variants of uncertain significance, have been reported with known clinical implications: *KIF1B* c.2480C>T is associated with increased susceptibility to neuroblastoma,³⁰ and *MFN2* c.749G>A was described in a CMT patient with no additional clinical data.³¹ Segregation analyses have not been performed for *KIF1B* c.2480C>T. The *MFN2* c.749G>A change was identified in SGT-142 and did not cosegregate with the disease. However, another mutation, c.2137_2143delATCGCCC in the *LRSAMI* gene, was detected and fully cosegregated with disease. In the case of using Sanger sequencing, only the most frequent CMT2 genes would have been analyzed and a definite genetic diagnosis would have been impossible, as the known pathological mutation in the *MFN2* gene did

not cosegregate with disease in the family of SGT-142 (fCMT-414).

The panel could be designed to be phenotype specific, with the aim of reducing the number of identified variants,³² but this approach requires that patients be supervised by neurologists with expertise in these neuropathies. However, a broader gene panel can be useful for clinicians with no expertise in CMT and/or HMN phenotypes because it generates the possibility of screening a relevant number of genes. The discovery of so many genes has enabled genetic diagnosis in many more patients, but there are still genes to be discovered. The genetics of HMN are poorly understood,⁵ even though >50 genes have been reported to be involved in CMT and related neuropathies. With regard to this, the high number of cases without a candidate mutation illustrates the complexity of the genetics associated with this group of neuropathies.

Many rare Mendelian diseases are characterized by broad genetic heterogeneity with a weak genotype–phenotype correlation. In these situations, a customized genetic screening panel is the best cost-effective diagnostic strategy. Panels of genes are already routine diagnostic tools for many disorders, but the field is quickly advancing. Exome sequencing will likely become a diagnostic tool in the coming years. Presently, the most important challenges are to generate a common database of variants that have been detected using next-generation sequencing from patients and healthy individuals to easily identify which variants are likely to be relevant, as well as to develop reliable functional tools to unravel the phenotypical consequences of any identified mutations.

Acknowledgments

We thank Dr. Salvador Martí and Laura Ramírez for technical support.

Supplemental Data

Supplemental material for this article can be found at <http://dx.doi.org/10.1016/j.jmoldx.2015.10.005>.

References

1. Skre H: Genetic and clinical aspects of Charcot–Marie–Tooth's disease. *Clinical Genetic* 1974, 6:98–118
2. Dyck P, Lambert EH: Lower motor and primary sensory neuron diseases with peroneal muscular atrophy. I. Neurologic, genetic, and electrophysiologic findings in hereditary polyneuropathies. *Arch Neurol* 1968, 18:603–618
3. Pareyson D, Marchesi C: Diagnosis, natural history, and management of Charcot-Marie-Tooth disease. *Lancet Neurol* 2009, 8:654–667
4. Szigeti K, Lupski JR: Charcot-Marie-Tooth disease. *Eur J Hum Genet* 2009, 17:703–710
5. Rossor AM, Kalmar B, Greensmith L, Reilly MM: The distal hereditary motor neuropathies. *J Neurol Neurosurg Psychiatry* 2012, 83:6–14
6. Saporta AS, Sottile SL, Miller LJ, Feely SM, Siskind CE, Shy ME: Charcot-Marie-Tooth disease subtypes and genetic testing strategies. *Ann Neurol* 2011, 69:22–33
7. Murphy SM, Laura M, Fawcett K, Pandraud A, Liu YT, Davidson GL, Rossor AM, Polke JM, Castleman V, Manji H, Lunn MP, Bull K, Ramdharry G, Davis M, Blake JC, Houlden H, Reilly MM: Charcot-Marie-Tooth disease: frequency of genetic subtypes and guidelines for genetic testing. *J Neurol Neurosurg Psychiatry* 2012, 83:706–710
8. Sivera R, Sevilla T, Vílchez JJ, Martínez-Rubio D, Chumillas MJ, Vázquez JF, Muelas N, Bataller L, Millán JM, Palau F, Espinós C: Charcot-Marie-Tooth disease: genetic and clinical spectrum in a Spanish clinical series. *Neurology* 2013, 81:1617–1625
9. Fridman V, Bundy B, Reilly MM, Pareyson D, Bacon C, Burns J, Day J, Feely S, Finkel RS, Grider T, Kirk CA, Herrmann DN, Laurá M, Li J, Lloyd T, Sumner CJ, Muntoni F, Piscoquito G, Ramchandren S, Shy R, Siskind CE, Yum SW, Moroni I, Pagliano E, Züchner S, Scherer SS, Shy ME; on behalf of the Inherited Neuropathies Consortium: CMT subtypes and disease burden in patients enrolled in the Inherited Neuropathies Consortium natural history study: a cross-sectional analysis. *J Neurol Neurosurg Psychiatry* 2015, 86:873–878
10. Genari AB, Borghetti VH, Gouvea SP, Bueno KC, dos Santos PL, dos Santos AC, Barreira AA, Lourenço CM, Marques W Jr: Characterizing the phenotypic manifestations of MFN2 R104W mutation in Charcot-Marie-Tooth type 2. *Neuromuscul Disord* 2011, 21:428–432
11. Sevilla T, Jaijo T, Nauffal D, Collado D, Chumillas MJ, Vílchez JJ, Muelas N, Bataller L, Domenech R, Espinós C, Palau F: Vocal cord paresis and diaphragmatic dysfunction are severe and frequent symptoms of GDAP1-associated neuropathy. *Brain* 2008, 131:3051–3061
12. Kabzinska D, Kochanski A, Drac H, Ryniewicz B, Rowinska-Marcinska K, Hausmanowa-Petrusewicz I: Autosomal recessive axonal form of Charcot-Marie-Tooth Disease caused by compound heterozygous 3'-splice site and Ser130Cys mutation in the GDAP1 gene. *Neuropediatrics* 2005, 36:206–209
13. Claramunt R, Sevilla T, Lupo V, Cuesta A, Millán JM, Vílchez JJ, Palau F, Espinós C: The p.R1109X mutation in SH3TC2 gene is predominant in Spanish Gypsies with Charcot-Marie-Tooth disease type 4. *Clin Genet* 2007, 71:343–349
14. Sevilla T, Martínez-Rubio D, Márquez C, Paradas C, Colomer J, Jaijo T, Millán JM, Palau F, Espinós C: Genetics of the Charcot-Marie-Tooth disease in the Spanish Gypsy population: the hereditary motor and sensory neuropathy-Russe in depth. *Clin Genet* 2013, 83:565–570
15. Houlden H, Laura M, Wavrant-De Vrieze F, Blake J, Wood N, Reilly MM: Mutations in the HSP27 (HSPB1) gene cause dominant, recessive, and sporadic distal HMN/CMT type 2. *Neurology* 2008, 71:1660–1668
16. Lassuthová P, Safka Brozkova D, Krutova M, Zavad'akova P, Rivotla C, Ivanek R, Mazanec R, Haberlová J, Speziani F, González MA, Züchner S, Seemen P: Identifying a new gene for CMT2 in a Polish family using whole exome sequencing. Presented at the 5th European and North American Charcot-Marie-Tooth Consortium Meeting, 2013 June 25–27, Antwerp, Belgium.
17. Kennerson ML, Pérez-Siles G, Kochanski A, Kidambi A, Drew AP, Kosinska J, Kabzinska D, Ploski R, Menezes M, Hausmanowa-Petrusewicz I, Züchner S, Nicholson GA: Stop-mutation in the MICAL1 gene identified by exome sequencing in combination with a useful previous linkage analysis in a Czech HMSN II family. Presented at the 5th European and North American Charcot-Marie-Tooth Consortium Meeting, 2013 June 25–27, Antwerp, Belgium.
18. Ionasescu VV, Searby C, Ionasescu R, Neuhaus IM, Werner R: Mutations of the noncoding region of the connexin32 gene in X-linked dominant Charcot-Marie-Tooth neuropathy. *Neurology* 1996, 47:541–544
19. Houlden H, Girard M, Cockerell C, Ingram D, Wood NW, Goossens M, Walker RW, Reilly MM: Connexin 32 promoter P2 mutations: a mechanism of peripheral nerve dysfunction. *Ann Neurol* 2004, 56:730–734

20. McKenna A, Hanna M, Banks E, Sivachenko A, Cibulskis K, Kernytsky A, Garimella K, Altshuler D, Gabriel S, Daly M, DePristo MA: The Genome Analysis Toolkit: a MapReduce framework for analyzing next-generation DNA sequencing data. *Genome Res* 2010, 20:1297–1303
21. Medina I, De Maria A, Bleda M, Salavert F, Alonso R, Gonzalez CY, Dopazo J: VARIANT: Command Line, Web service and Web interface for fast and accurate functional characterization of variants found by Next-Generation Sequencing. *Nucleic Acids Res* 2012, 40:W54–W58
22. Richards S, Aziz N, Bale S, Bick D, Das S, Gastier-Foster J, Grody WW, Hegde M, Lyon E, Spector E, Voelkerding K, Rehm HL: Standards and guidelines for the interpretation of sequence variants: a joint consensus recommendation of the American College of Medical Genetics and Genomics and the Association for Molecular Pathology. *Genet Med* 2015, 17:405–424
23. Ruark E, Snape K, Humburg P, Loveday C, Bajrami I, Brough R, et al; Breast and Ovarian Cancer Susceptibility Collaboration; Wellcome Trust Case Control Consortium, Turnbull C, Reis-Filho JS, Ashworth A, Antoniou AC, Lord CJ, Donnelly P, Rahman N: Mosaic PPM1D mutations are associated with predisposition to breast and ovarian cancer. *Nature* 2013, 493:406–410
24. Berglund EC, Lindqvist CM, Hayat S, Overnas E, Henriksson N, Nordlund J, Wahlberg P, Forestier E, Lönnerholm G, Syvänen AC: Accurate detection of subclonal single nucleotide variants in whole genome amplified and pooled cancer samples using HaloPlex target enrichment. *BMC Genomics* 2013, 14:856
25. Pihlstrom L, Rengmark A, Bjornara KA, Toft M: Effective variant detection by targeted deep sequencing of DNA pools: an example from Parkinson's disease. *Ann Hum Genet* 2014, 78:243–252
26. Green A, Green H, Rehnberg M, Svensson A, Gunnarsson C, Jonasson J: Assessment of HaloPlex amplification for sequence capture and massively parallel sequencing of arrhythmogenic right ventricular cardiomyopathy-associated genes. *J Mol Diagn* 2015, 17:31–42
27. Blumen SC, Astord S, Robin V, Vignaud L, Toumi N, Cieslik A, Achiron A, Carasso RL, Gurevich M, Braverman I, Blumen N, Munich A, Barkats M, Viollet L: A rare recessive distal hereditary motor neuropathy with HSF1 chaperone mutation. *Ann Neurol* 2012, 71:509–519
28. Hoyer H, Braathen GJ, Busk OL, Holla OL, Svendsen M, Hilmarsen HT, Stand L, Skjelbred CF, Russell MB: Genetic diagnosis of Charcot-Marie-Tooth disease in a population by next-generation sequencing. *Biomed Res Int* 2014, 2014:210401
29. Cooper GM, Shendure J: Needles in stacks of needles: finding disease-causal variants in a wealth of genomic data. *Nat Rev Genet* 2011, 12: 628–640
30. Schlisio S, Kenchappa RS, Vredevelde LC, George RE, Stewart R, Greulich H, Shahriari K, Nguyen NV, Pigny P, Dahia PL, Pomeroy SL, Maris JM, Look AT, Meyerson M, Peeper DS, Carter BD, Kaelin WG Jr: The kinesin KIF1Bbeta acts downstream from EglN3 to induce apoptosis and is a potential 1p36 tumor suppressor. *Genes Dev* 2008, 22:884–893
31. Verhoeven K, Claeys KG, Zuchner S, Schroder JM, Weis J, Ceuterick C, et al: MFN2 mutation distribution and genotype/phenotype correlation in Charcot-Marie-Tooth type 2. *Brain* 2006, 129: 2093–2102
32. Rossor AM, Polke JM, Houlden H, Reilly MM: Clinical implications of genetic advances in Charcot-Marie-Tooth disease. *Nat Rev Neurol* 2013, 9:562–571